

# DEFENDER

Tough with high performance



## DEFENDER STANDARD

STANDARD PURPOSE FRICTION HINGE

- **NEW extended enclosed end cap** to enhance weather sealing
- Long and reliable working life tested to 30,000 cycles
- Asymmetric location system for reliable weather sealing to BS6375 Part 1
- Patented lipped slider for enhanced smooth operation
- **NEW handed 'profiled' vent arm** further enhancing weather seal
- Easy friction adjustment without metal to metal contact
- Unique patented, robust cam friction device eliminates any risk of friction screw misuse
- Available in ferritic 430\* as standard or austenitic 304\* stainless steel for enhanced corrosion resistance
- Available with built in restrictors
- 10 year guarantee (details available upon request)

▼ **SMOOTH OPERATION**  
 Thermoplastic components for long life

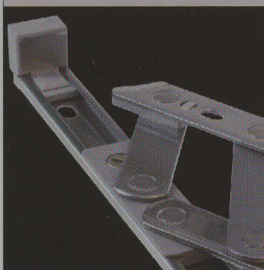

▼ **LONG LIFE**  
 Defender and Vector hinges have been proven to 30,000 full cycles

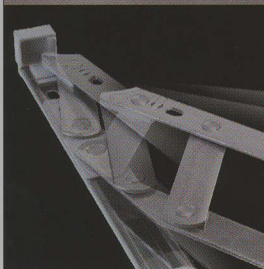

▼ **WORLD'S BEST!**  
 The Defender is the World's best selling friction hinge

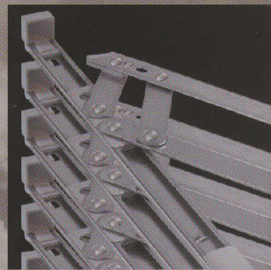

\* Standard Ferritic (was 430) steel to BS EN ISO 10088/2 Grade 1.4016 or Austenitic (was 304) stainless steel to BS EN ISO 10088/2 Grade 1.4301 for enhanced corrosion resistance.



# DEFENDER

## Product Specification

### PRODUCT SPECIFICATION

- **NEW slot hole slot** format will provide the ability to adjust the vent more easily
- **NEW increased carrying capacity** on 20" and 24" top hung hinges
- Defender Highline variants for deeper profiles with cavities between 16mm and 18mm
- Defender Slimline; engineered for narrower hardware channels
- Drilling jigs for all sizes are available to order
- **NEW to meet the ever increasing demand for larger windows the EDTH24 is available for large heavy top hung vents.**

Note: As with all types of friction hinges, friction cannot be provided until the slider moves, therefore when limiting the opening of top hung vents to angles of 10° or less, a separate device will be required to prevent the window from closing.

When fitting the EDTH24 and its variants, pull in blocks/locking wedges/snubbers must be fitted 100mm from each corner and then across the top as required to aid weather sealing.

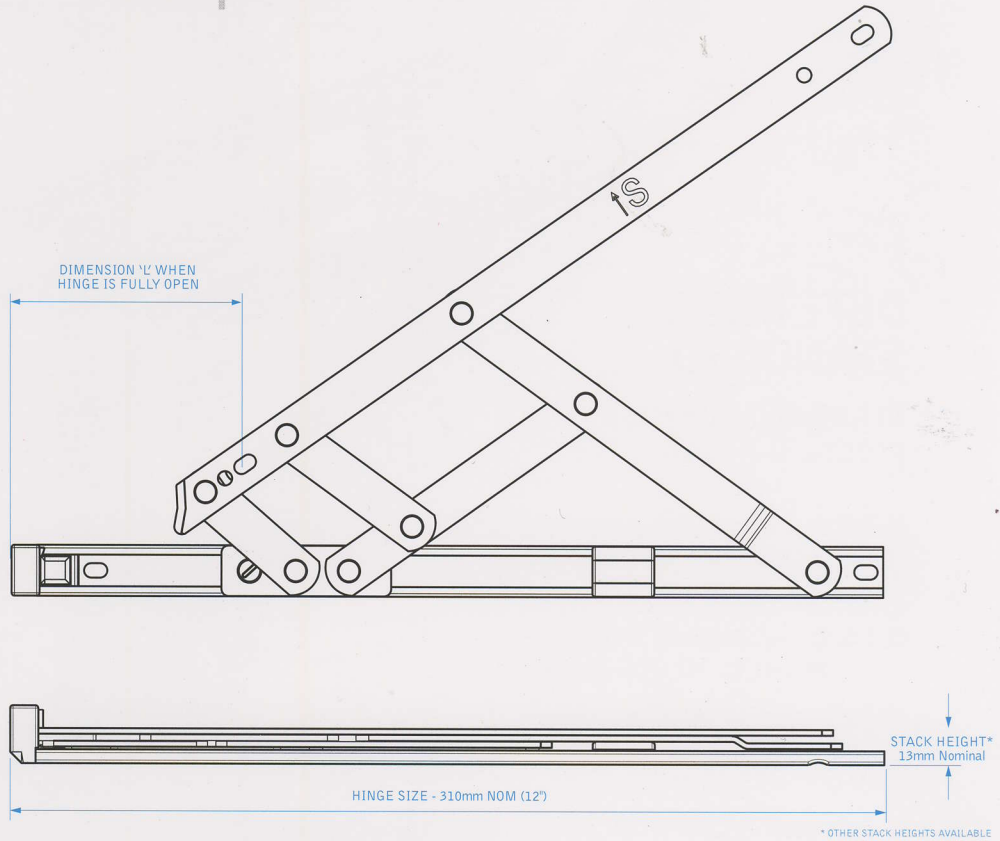

#### DEFENDER STANDARD

Hinge Size (Top Hung) (in/mm)	Max Vent Weight (lb/Kg)	Max Vent Height (in/mm)	Min Vent Height (in/mm)	Hinge Dimension 'L' (in/mm)	Opening Angle (+/- 2.5°)
6/159	22/10	12/300	6/150	2.48/63	50°
8/209	26/12	14/350	8/200	4.69/119	65°
10/259	35/16	16/400	11/275	5.15/131	80°
12/310	44/20	22/550	14/350	6.45/164	80°
16/412	46/21	29/780	20/500	9.4/239	80°
20/513	57/26	43/1100	27/700	8.46/215	50°
24/615	88/40	51/1300	33/850	6.14/156	37.5°
H24/615	110/50	59/1500	33/850	6.14/156	27°
Hinge Size (Side Hung)	Max Vent Width	Min Vent Width			
8/209	39/18	15.7/400	8/200	7.20/183	65°
12/310	48/22	23.6/600	12/300	6.77/172	60°
16/412	53/24	27.6/700	16/400	6.69/170	60°



Due to our policy of continual improvement we reserve the right to alter specifications without notice. It is the responsibility of the window manufacturer to ensure that the finished window meets the required performance and safety specification.

All transactions are subject to our standard conditions of supply, which are available on request.